

New!

Molded Pressure Regulator To Control System Downstream Pressure Series "PRHM" – 1/2" Size Set Pressures to 125 PSI

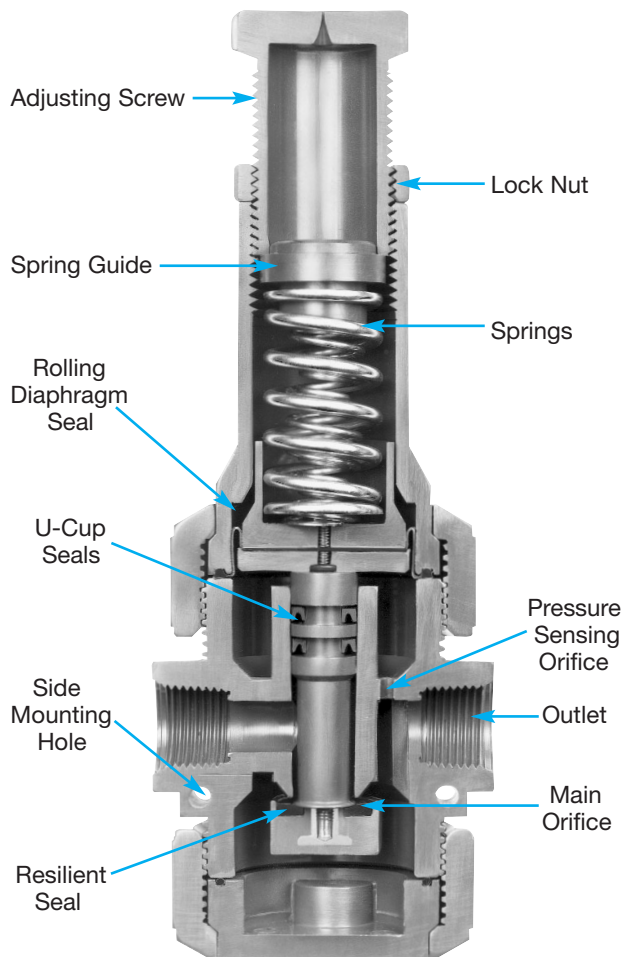

Superior Features:

- For corrosive and ultra-pure liquid applications.
- Converts varying or excessive inlet pressure (to 150 PSI) to pre-determined downstream pressure.
- Automatically regulates and prevents downstream pressure from exceeding the maximum desired set point so equipment/flow system operates safely and effectively.
- Large surface area of rolling diaphragm design assures highly sensitive operation.
- Adjustable downstream settings from 5 to 125 PSI.
- Diaphragm isolates spring from media.
- Rugged one-piece molded construction and U-cup seals eliminate leakage.
- No external metal fasteners – ideal for corrosive environments.
- Mounting holes to facilitate side or bottom mounting.
- Optional ports for gauge taps, sensing area flush.

Materials of Construction:

These molded pressure regulators are available in PVC with seals of FKM or EPDM. For other materials consult factory. Inlet and outlet threads are 1/2" NPT female.

Operation:

Series PRHM pressure regulators prevent downstream pressure from exceeding the desired set pressure. Regulator will remain closed as long as set pressure is maintained. As equipment or valves downstream of the regulator begin to open and demand flow, the downstream pressure begins to fall and the regulator begins to open. As valves or equipment downstream open further the pressure regulator continues to open, until its maximum

opening is reached. As the process is reversed, downstream pressure begins to increase and the regulator starts closing. When the downstream pressure again reaches set pressure the regulator closes bubble-tight.

IMPORTANT: It should be noted from the preceding explanation that a pressure regulator does not maintain a specific downstream pressure, but only prevents the downstream pressure from exceeding a set point.

SERIES PRHM PRESSURE REGULATOR

Design:

Plast-O-Matic Series PRHM Pressure Regulators are designed to handle corrosive and ultra-pure liquids with inlet pressures up to 150 PSI at 75°F. Standard downstream set pressure range is 5 to 125 PSI. The normally-open regulators incorporate a poppet seat at the valve orifice to prevent sticking and affecting the sensing of the downstream line pressure. Also, one piece body construction eliminates internal leakage that could cause the set pressure to creep beyond a safe limit. A

unique, large-surface rolling diaphragm seal isolates the spring chamber from downstream pressure sensing liquid. This unique design in conjunction with a pressure balanced, reinforced shaft assures smooth performance and stable control. Tapped holes ($1/4 - 20$) are provided on the bottom, and through holes on the sides to provide easy mounting. Hubs for optional use as a gauge port, or as a sensing area flush, are molded on the body.

SERIES PRHM DIMENSIONS

SIZE	A		B		C		D		TAPPED MOUNTING HOLES				THROUGH MOUNTING HOLES				I	
	In.	mm	In.	mm	In.	mm	In.	mm	In.	mm	Thread Size	Depth In.	Depth mm	In.	mm	In.		mm
	1/2	1 ^{3/4}	44.5	6 ^{1/2}	165	2 ^{1/8}	54	3 ^{3/16}	81	1 ^{1/4}	32	1/4-20	.375	9.5	1 ^{1/2}	38		2 ^{5/16}

Dimensions:

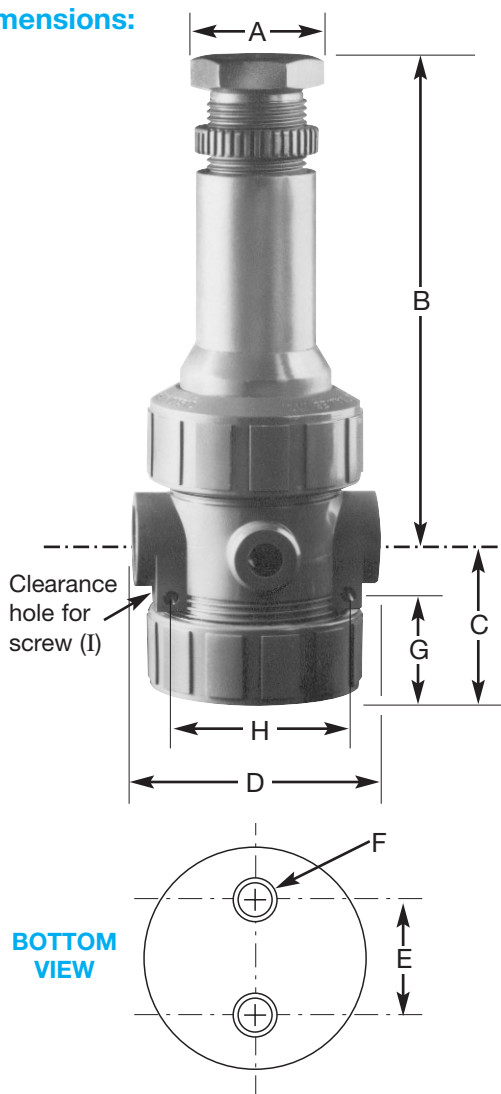

Performance Curve:

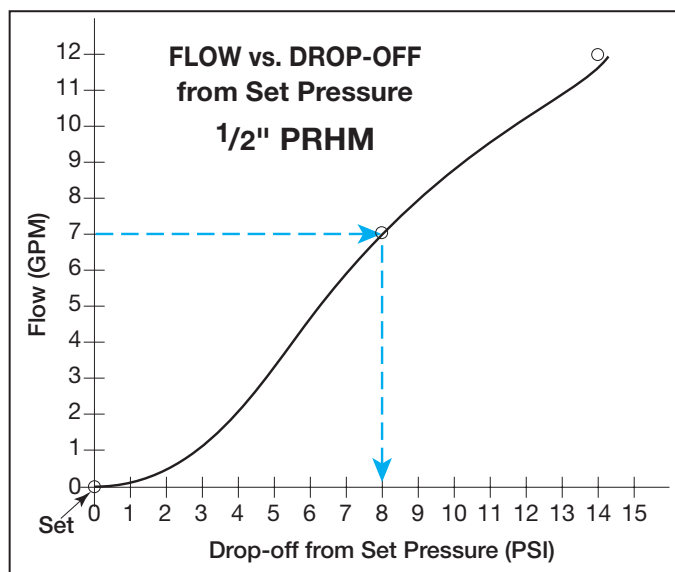

NOTE: Refer to Catalog PR, PRE and PRH for information on other Pressure Regulators in our Line or contact Plast-O-Matic

BODY MATERIAL	SEAL MATERIAL	MODEL NUMBER
PVC	EPDM	PRHM050-EP-PV
PVC	FKM	PRHM050-V-PV

PLAST-O-MATIC
VALVES, INC.

1384 Pompton Avenue, Cedar Grove, NJ 07009-1095
(973) 256-3000 • Fax (973) 256-4745
www.plastomatic.com • info@plastomatic.com

AUTHORIZED PLAST-O-MATIC DISTRIBUTOR